

A DIN cased 6-digit up/down counter with high efficiency LED displays behind a red filter, giving a high contrast display under all lighting conditions. Besides normal counting from input pulses, the display may also be preset from thumbwheel or other BCD switches. Outputs include multiplexed BCD, carry, zero and equals.

- 🌀 11mm (0.43") Digit Height
- 🌀 DIN Cased
- 🌀 Presetable Display
- 🌀 Internal 'Register'



### TIMER/FREQUENCY METER OPTION

For applications requiring time/frequency counter measurements, a similar universal product is available under stock number UCT 600, which may be user or factory configured to provide unit counting, timing or frequency counting functions. The sample rate/frequency may be easily modified by the user/factory. A separate data sheet is available for this product.

Specification	Min.	Typ.	Max.	Unit
Supply voltage	10	12	15	V
Supply current		180		mA
Supply current with display blanked		25	40	mA
Input impedance		20		kilohms
Input signal level	2		±10	V
I/P frequency (counter)	1	1.5		MHz
I/P frequency (compare - register)	100	150		KHz
Display reading			999999	counts
Operating temperature range	0		50	°C

### CONNECTOR SOURCING GUIDE

**METHOD** Edge Connector - Lascar Stock No. EC 24 DS

### DIMENSIONS All dimensions in mm (inches)

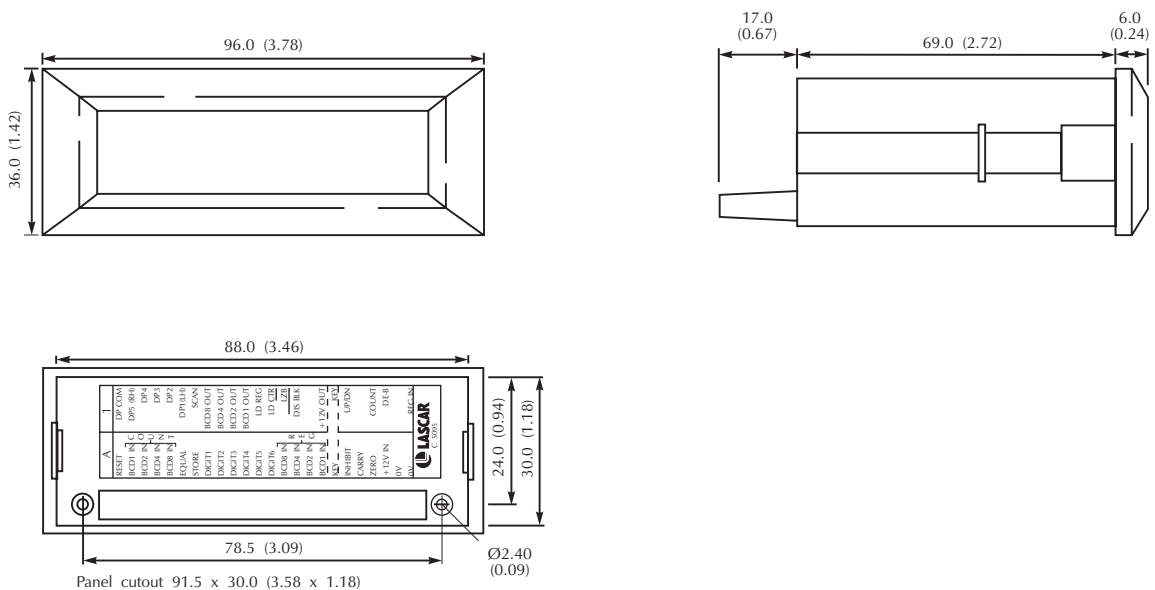

## PIN FUNCTIONS

1. DP COM Connect to required decimal point.
2. DP5 (RH) 99999.9
3. DP4 9999.99
4. DP3 999.999
5. DP2 99.9999
6. DP1 (LH) 9.99999
7. SCAN The internal scan oscillator has a nominal free running frequency of 10KHz. This may be reduced by the addition of a capacitor between the SCAN pin and V+, or the scan can be overdriven by an external oscillator up to 20KHz.
- 8., 9, 10, 11 BCD8 out, BCD4 out, BCD2 out, BCD1 out. Counter BCD outputs, data is valid when the positive transition of the relevant Digit Select output occurs.
12. LD REG Take to V+ to load register with register BCD inputs.
13. LD CTR Take to V+ to load counter with counter BCD inputs.
14. LZ BK Take to 0V to blank leading zeros. Take to V+ or leave floating if not required.
15. SET/DB For normal operation leave floating or take to V+. Taking to 0V stops the multiplex clock and blanks the display, but the counter continues to operate. In this mode the digit select is held at the MSD.
16. N.C
17. +12V Positive power supply.
18. KEY Key slot in PCB (corresponds with Pin T) to enable correct orientation of edge connector.
19. UP/DN When at V+ or floating the counter counts up. When at 0V the counter counts down.
20. N.C
21. COUNT Count Input. The Counter counts up or down on the negative edge of the count input.
22. DE BOUN 'De-bounce' circuit for noisy environments at low frequency. If required, it should be connected to pin 21.
23. N.C
24. REG IN Input for un-regulated 14 - 24V D.C. supply. Can only be used when the associated regulating components are fitted.
- A. RESET Will reset the counter and display when taken to V+ (register is not reset).
- B, C, D, E BCD1 in, BCD2 in, BCD4 in, BCD8 in. Counter BCD inputs. Counter will load when the positive transition of the relevant Digit Select output occurs.
- F. EQUAL This output will go high for one count period when the contents of the counter and register are equal.
- G. STORE Taking to V+ will hold display but still allow the counter to acquire data. Display is updated when STORE is at 0V or floating.
- H, J, K, L, M, N DIGIT1, DIGIT2, DIGIT3, DIGIT4, DIGIT5, DIGIT6. Digit Select outputs. BCD data (ie. counter BCD in/ outputs, register BCD inputs) is valid on positive transition of relevant Digit Select output.
- T. KEY Key slot in PCB (corresponds with Pin 18) to enable correct orientation of edge connector.
- U. INHIBIT When at V+, counter is inhibited and display is held. To count normally leave floating or take to 0V.
- V. CARRY This output will go high for one count pulse when the count is advanced from 999999 to 000000 (if counting up), and from 000000 to 999999 (if counting down). This allows direct cascading of counters.
- W. ZERO This output will go high for one count pulse when the content of the counter is 000000.
- X. +12V IN Positive power supply.
- Y, Z. 0V Negative power supply.

## OPERATING MODE

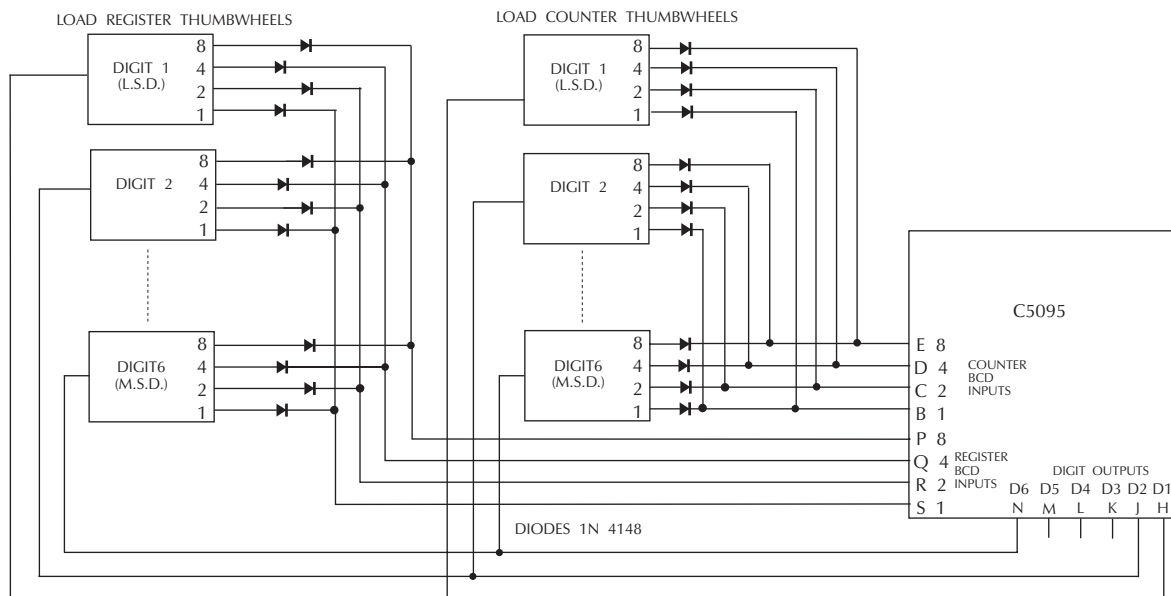

12 x true BCD switches required (6 shown for clarity).

The diagram illustrates the use of two banks of thumbwheel switches for applications where the counter and register contents need to be independently set. However only one bank of switches needs to be used to set the register, because the load register functions remain independent by means of their respective control inputs.